

## enzie eco 1500 SPIRAL STAIR

### STANDARD SPECIFICATIONS

#### CONSTRUCTION

The stair is spiral with solid time treads supported by box sections which are made from 1.6 mm mild steel. Column is 4.9 mm thick by 101.2 mm diameter mild steel. The handrail is tubular 22 mm OD by 1.6 mm mild steel and balusters are 8 mm OD by 22 mm steel. The stair structure is mechanically jointed on site, requiring no site welding or finishing. The maximum length of any component is slightly more than one metre, and weight is less than 15 kg. The stair can be assembled in a clockwise or an anticlockwise direction. The stair base-plate fits on top of the floor surface before or after floor coverings. The pre-finished stair, when erected, is complete; no further finishing is required by others; no unsightly welds, nuts or bolts are showing.

#### SURFACE TREATMENT

Stairs are supplied pre-finished in a high quality black baked polyester powder coating. Timber treads are made of durable plywood 40 mm thick. The stairs are suitable for internal use only.

#### INSTALLATION

Mechanical jointing and factory pre-finishing of the stair allows installation after all other trades, including floor coverings, have been completed in the stairwell and adjoining area. Installation can be carried out by a local contractor or handyman. Installation instructions are supplied with stair kit. The stair kit includes all nuts, bolts and accessories required for installation. Optional installation DVD is also available.

#### SAFETY

The synthetic rubber anti-skid button, applied to the top of stair treads ensures safe access. Handrail balusters on the staircase are spaced as standard at a maximum of 120 mm, and on the balcony balustrade are spaced at a maximum of 120 mm. Optionally extra gate can be supplied for the top or the bottom of the staircase

### DETAILS OF enzie 1500 mm DIAMETER SPIRAL STAIR

#### GEOMETRY OF STAIRS

Stair is made with risers between 208 and 220 mm 14 steps to circle at 25.7 degrees. The going measured at 7/10ths. of the clear width is 219 mm and slope relationship is 639 to 659.

#### TREADS AND RISES

Treads are uniform shape and size. Risers are of uniform height between 208 mm and 220 mm as required by client's application. Anti-skid button for each tread is supplied. This button is replaceable if wear should occur.

#### HEAD ROOM

Using standard 90 degree landing 120 mm thick with 210 mm riser clear headroom is 2030 mm. Every 1 mm added to riser adds 12 mm to headroom.

#### HANDRAIL

Continuous and uninterrupted handrail is provided on one side and is at a vertical height of 966 mm minimum above the nosing of the tread. Balcony railing is 1000 mm above floor.

#### WIDTH

The width of stair free of obstruction is 626 mm.

#### BUILDING APPROVALS

The stair is fully compliant with the deem to satisfy component of the Building Code of Australia. Procedure for building approval is to include a copy of Data Sheet and Accreditation Certificate for the system with drawings showing location of proposed installation (with your required documentation) to the local building authority for their approval. Computations available on request for submission to building Authority.

#### PACKED WEIGHT

Approximately 16 kg per riser.

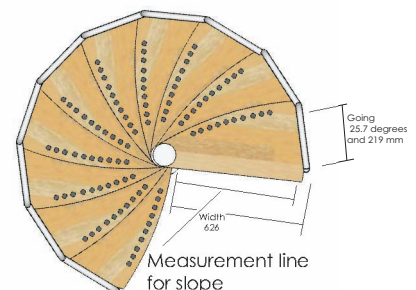
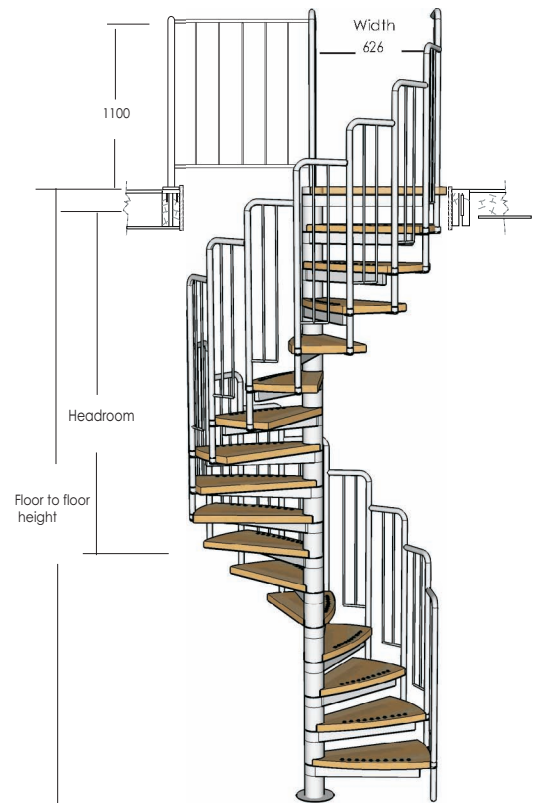
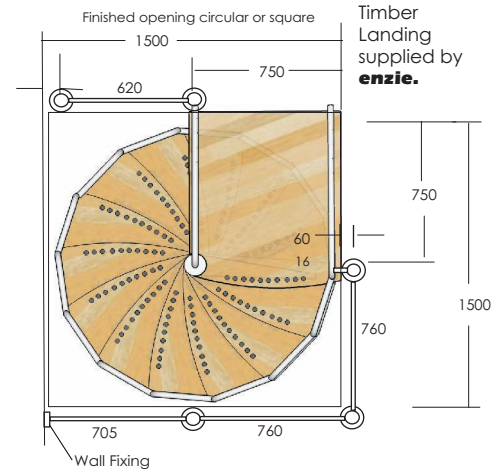

## DATA SHEET enzie eco 1500 SPIRAL STAIR

## Fixing Detail

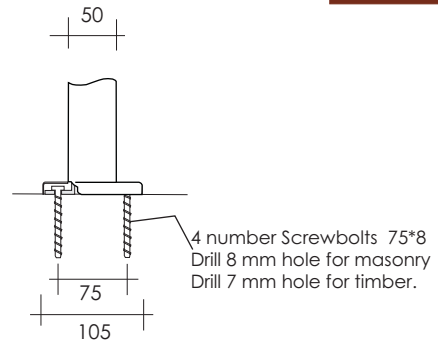
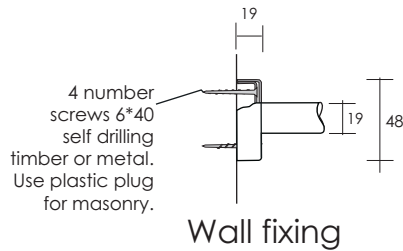

## Landing Detail

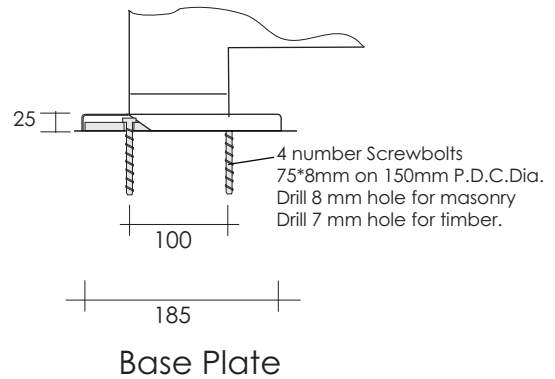
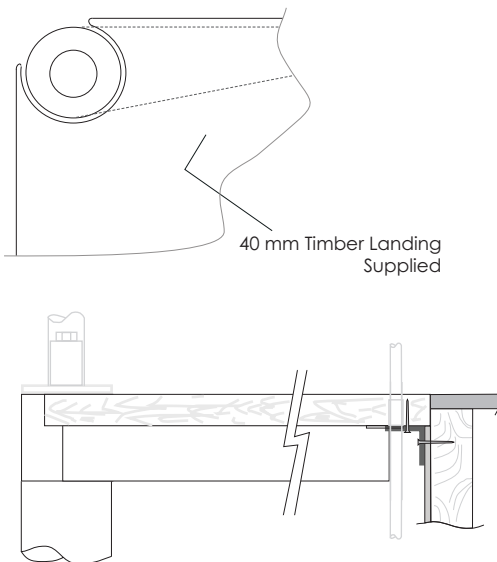

## Setting out examples

1500 Diameter 208 mm to 220 mm Riser 14 Treads to circle at 25.7 Degrees

Floor to Floor Height	2640	2860	3080	3300	3520	3740	3960	4180	4400	4620	4840
Number of risers	12	13	14	15	16	17	18	19	20	21	22
Number of treads	11	12	13	14	15	16	17	18	19	20	21
Going	282	308	334	360	385	411	437	463	488	514	540
14 Treads to circle at 25.7 Degrees											

### Some typical top landing examples

